

INSTALLATION MANUAL

Z-SG / Z-SG2

Strain Gauge converter

EN



SENECA

SENECA s.r.l.

Via Austria, 26 – 35127 – PADOVA – ITALY

Tel. +39.049.8705355 - 8705359 - Fax +39.049.8706287

For manuals in other languages and the configuration software, visit www.seneca.it/products/z-sg
or www.seneca.it/products/z-sg2



MODULE LAYOUT

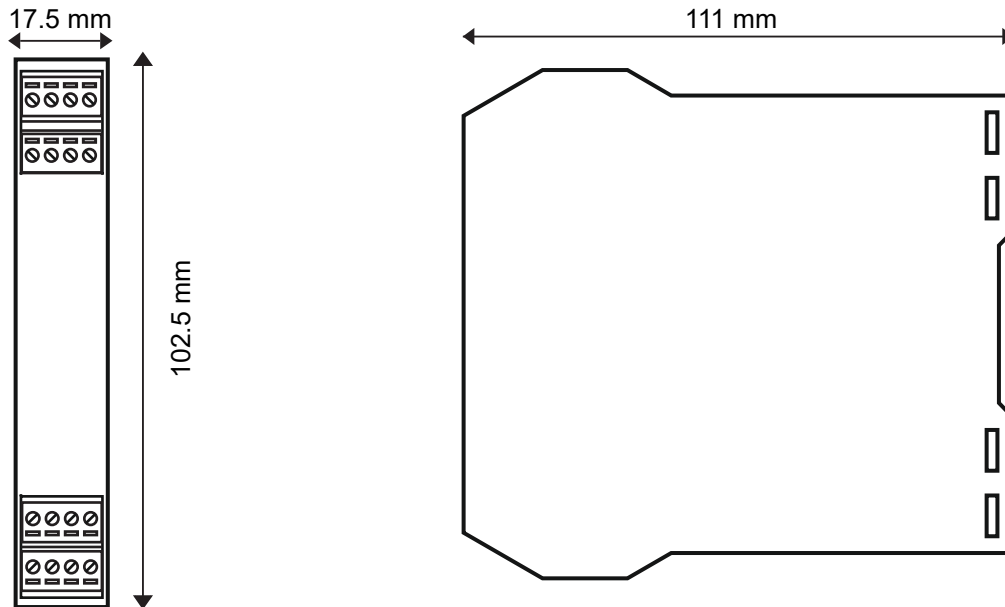



Dimensions LxHxD 17.5 x 102.5 x 111 mm; **Weight:** 110 g; **Enclosure:** PA6, black





SIGNALS VIA LED ON FRONT PANEL

LED	STATUS	LED meaning
PWR Green	ON	The device is powered correctly
FAIL yellow	On	Faulty
RX Red	Flashing	Receipt of packet completed
RX Red	ON	Anomaly / Check connection
TX Red	Flashing	Transmission of packet completed

PRELIMINARY WARNINGS

The word **WARNING** preceded by the symbol  indicates conditions or actions that put the user's safety at risk. The word **ATTENTION** preceded by the symbol  indicates conditions or actions that might damage the instrument or the connected equipment.

The warranty shall become null and void in the event of improper use or tampering with the module or devices supplied by the manufacturer as necessary for its correct operation, and if the instructions contained in this manual are not followed.

	WARNING: The full content of this manual must be read before any operation. The module must only be used by qualified electricians. Specific documentation is available at www.seneca.it/products/z-sg2
	The module must be repaired and damaged parts replaced by the Manufacturer. The product is sensitive to electrostatic discharges. Take appropriate measures during any operation.
	Important: Obstructing ventilation slots with any object is prohibited. Installing the module next to devices that generate heat is prohibited.
	Electrical and electronic waste disposal (applicable in the European Union and other countries with recycling). The symbol on the product or its packaging shows the product must be surrendered to a collection centre authorized to recycle electrical and electronic waste.

 **ATTENTION:** for further information regarding register settings or other details, refer to the USER MANUAL downloadable from www.seneca.it/products/z-sg2

TECHNICAL SPECIFICATIONS

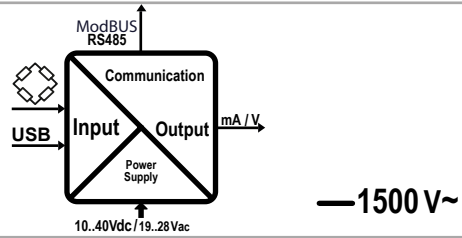
STANDARDS	EN61000-6-4 Electromagnetic emissions, industrial environment. EN61000-6-2 Electromagnetic immunity, industrial environment. EN61010-1 Safety
INSULATION	 <p>WARNING the maximum working voltage between any terminal and ground must be less than 50 Vac / 75Vdc</p> <p>—1500 V~</p>
ENVIRONMENTAL CONDITIONS	<i>Temperature:</i> -10 – + 65°C <i>Humidity:</i> 30%– 90% non condensing. <i>Altitude:</i> up to 2000 m above sea level <i>Storage temperature:</i> -20 + 85° <i>Protection degree:</i> IP20.
ASSEMBLY	IEC EN60715, 35mm DIN rail in vertical position.
CONNECTIONS	3-way removable screw terminals, pitch 5 mm Rear connector IDC10 for DIN bar 46277 front micro USB
POWER SUPPLY	<i>Voltage:</i> 10 – 40 Vdc; 19 – 28 Vac 50 – 60 Hz <i>Absorption:</i> Typical: 1.5 W @ 24Vdc, Max: 2 W
ANALOGUE INPUT	<i>Input type:</i> 4- or 6-wire differential measurement input <i>Input impedance:</i> > 1 MΩ <i>Full scale:</i> ± 10 mV / ± 320 mV <i>Error:</i> 0.01% of the electrical full scale in “factory calibration” mode * Thermal stability: 0.0025%/C° of full scale. <i>Insulation:</i> 1500 Vac three-ways
COMMUNICATION	<i>Serial communication ports:</i> RS485, 2400 - 115200 Baud / USB 38400 Baud Address: 01, parity: NO, Data: 8 Stop bits: 1 <i>Protocol:</i> Modbus Rtu
LOAD CHARACTERISTICS	<i>Supply voltage:</i> 5 Vdc <i>Minimum impedance:</i> 87 Ω equivalent (possibly deriving from several load cells) <i>Sensitivity:</i> From ±1 mV/V to ±64 mV/V <i>Load cells:</i> 4 or 6 wires
ANALOGUE OUTPUT	<i>Voltage output:</i> Configurable between 0 - 10 Vdc, minimum load resistance 2 kΩ <i>Current input:</i> Configurable between 0 - 20 mA, maximum load resistance: 500 Ω <i>Retransmission error:</i> 0.1 % of maximum field <i>Response time (10%..90%):</i> 5 ms
DIGITAL IN/OUT	<i>Opto-insulated digital input:</i> Min. voltage: 12 V / Max. voltage: 30 V <i>Opto-insulated digital input:</i> Min. current: 50 mA / Max. voltage: 30 V
OTHER SPECIFICATIONS	<i>Input type:</i> 4- or 6-wire differential measurement input <i>Input impedance:</i> > 1 MΩ <i>Full scale:</i> ± 10 mV / ± 320 mV

* In the case of “calibration with sample weight” mode, the accuracy is given by the linearity error (0.003% of the electric full scale)

DESCRIPTION OF COMMON FUNCTIONS

- Power supply and serial connection wiring facilitated by means of a bus housed in the DIN rail.
- Communication can be configured by DIP-switch or software.
- RS485 serial communication or via USB with MODBUS-RTU protocol.
- Protection against ESD discharges up to 4 kV.
- 1500 Vac insulation: between input and all other circuits, between communication and power supply and between retransmitted output and power supply.
- Analogue output in voltage or current, with programmable limits.
- Cell calibration with sample weight, not required in case of known cell sensitivity.
- Configurable digital I/O.
- Rejection at 50 Hz and 60 Hz.
- Stable weighing signal via digital output/Modbus register.
- Remote tare writing in volatile and/or non-volatile memory via digital input/Modbus register
- Strain gauge directly powered by the instrument.
- Ratiometric measurement.
- Sensitivity from ± 1 to ± 64 mV/V.
- Complete configurability with dedicated EASY SETUP software.
- Cell calibration and configuration using Easy Setup software.

DESCRIPTION OF FUNCTIONS DEDICATED TO THE Z-SG2 INSTRUMENT

- Configurable resolution (max, auto, customized).
- Sampling frequency can be set from 5.4 Hz to 1365.3 Hz.
- Alarm can be activated when a set threshold is exceeded.
- Measurement that can be stabilized by means of a special noise filter.
- Available sizes in both integer and floating point.
- Piece counting function
- Upgradeable firmware.
- Min/max values of the net weight
- Automatic tare reset

SETTING THE SW1 DIP-SWITCHES: Z-SG / Z-SG2 VERSION

The position of the DIP-switches defines the Modbus communication parameters of the module: Address and Baud Rate
The following table shows the values of the Baud Rate and the Address according to the setting of the DIP-switches:

DIP-Switch status												
SW1 POSITION		BAUD RATE	SW1 POSITION		ADDRESS							
1	2		3	4		5	6	7	8			
<input type="checkbox"/>	<input type="checkbox"/>	-----	9600	--	<input type="checkbox"/>	<input type="checkbox"/>	<input type="checkbox"/>	<input type="checkbox"/>	<input type="checkbox"/>	<input type="checkbox"/>	<input type="checkbox"/>	#1
<input type="checkbox"/>	<input type="checkbox"/>	-----	19200	--	<input type="checkbox"/>	<input type="checkbox"/>	<input type="checkbox"/>	<input type="checkbox"/>	<input type="checkbox"/>	<input type="checkbox"/>	<input type="checkbox"/>	#2
<input type="checkbox"/>	<input type="checkbox"/>	-----	38400	<input type="checkbox"/>	<input type="checkbox"/>	<input type="checkbox"/>	<input type="checkbox"/>	<input type="checkbox"/>	<input type="checkbox"/>	<input type="checkbox"/>	#...
<input type="checkbox"/>	<input type="checkbox"/>	-----	57600	--	<input type="checkbox"/>	<input type="checkbox"/>	<input type="checkbox"/>	<input type="checkbox"/>	<input type="checkbox"/>	<input type="checkbox"/>	<input type="checkbox"/>	#63
<input type="checkbox"/>	<input type="checkbox"/>	<input type="checkbox"/>	<input type="checkbox"/>	<input type="checkbox"/>	<input type="checkbox"/>	<input type="checkbox"/>	<input type="checkbox"/>	<input type="checkbox"/>	<input type="checkbox"/>	<input type="checkbox"/>	<input type="checkbox"/>	From EEPROM
			From EEPROM									From EEPROM

Note: When DIP switches 3 to 8 are OFF, the communication settings are taken from programming (EEPROM).

SETTING THE SW3 DIP-SWITCHES Z-SG / Z-SG2 VERSION

Status of the SW3 dip-switches			
SW3 POSITION		SW3 POSITION	
1	Ground RS485	2	Terminator RS485
<input type="checkbox"/>	Connected	<input type="checkbox"/>	Inserted
<input type="checkbox"/>	Disconnected	<input type="checkbox"/>	Disengaged

Note 1: Since the GND terminal of the RS485 port and the negative terminal of the analogue output are not isolated from each other, in order to use the analogue outputs of several instruments simultaneously and connected to each other via the RS485 port, it is necessary to disconnect the GND terminal of the RS485 port via the dedicated dip-switch (SW3).

Note 2: The RS485 line must be terminated only at the ends of the communication line.

SETTING THE SW2 DIP-SWITCHES: Z-SG VERSION

SW2 DIP-SWITCH SETTING			
1	<u>DIGITAL I/O TYPE + CALIBRATION BUTTON ENABLING</u>		
<input type="checkbox"/>	Selects digital input. Enables calibration button		
<input type="checkbox"/>	Selects digital output		
2	3	<u>OUTPUT</u>	
<input type="checkbox"/>	<input type="checkbox"/>	0 - 10 V	
<input type="checkbox"/>	<input type="checkbox"/>	0 - 5 V	
<input type="checkbox"/>	<input type="checkbox"/>	0 - 20 mA	
<input type="checkbox"/>	<input type="checkbox"/>	4 - 20 mA	
4	5	<u>METHOD OF USE/CALIBRATION</u>	
<input type="checkbox"/>	<input type="checkbox"/>	Selects how to use 2 and 4	
<input type="checkbox"/>	<input type="checkbox"/>	Selects how to use 1 and 3	
<input type="checkbox"/>	<input type="checkbox"/>	Acquisition of the tare value via button or Digital input (2 and 4)	
<input type="checkbox"/>	<input type="checkbox"/>	Manual cell calibration mode (1 and 3)	
6	7	8	<u>CELL SENSITIVITY</u>
<input type="checkbox"/>	<input type="checkbox"/>	<input type="checkbox"/>	± 1 mV/V
<input type="checkbox"/>	<input type="checkbox"/>	<input type="checkbox"/>	± 2 mV/V
<input type="checkbox"/>	<input type="checkbox"/>	<input type="checkbox"/>	± 4 mV/V
<input type="checkbox"/>	<input type="checkbox"/>	<input type="checkbox"/>	± 8 mV/V
<input type="checkbox"/>	<input type="checkbox"/>	<input type="checkbox"/>	± 16 mV/V
<input type="checkbox"/>	<input type="checkbox"/>	<input type="checkbox"/>	± 32 mV/V
<input type="checkbox"/>	<input type="checkbox"/>	<input type="checkbox"/>	Sensitivity from ModBus register SENSE_RATIO (40044). Real non-integer values can also be set.

ModBUS CONNECTION RULES

- 1) Install the modules in the DIN rail (120 max)
- 2) Connect the remote modules using cables of an appropriate length. The following table shows cable length data:
 - Bus length: maximum length of the Modbus network according to the Baud Rate. This is the length of the cables that connect the two farthest modules (see Diagram 1).
 - Derivation length: maximum length of a derivation 2 m (see Diagram 1).

Diagram 1

Bus length	Derivation length
1200 m	2 m

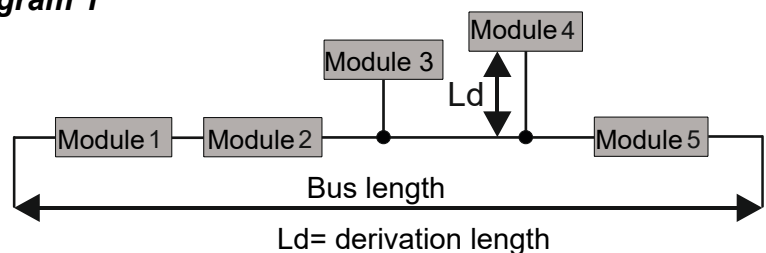

For maximum performance, it is recommended to use special shielded cables, such as BELDEN 9841.

INSTALLATION REGULATIONS

The module has been designed for vertical installation on a DIN 46277 rail. For optimal operation and long life, adequate ventilation must be provided. Avoid positioning ducting or other objects that obstruct the ventilation slots. Avoid mounting modules over heat-generating equipment. Installation in the bottom part of the electrical panel is recommended.

Insertion in the DIN rail

As shown in figure:

1. Insert the IDC10 rear connector of the module on a free slot of the DIN rail (the insertion is univocal since the connectors are polarized).
2. To secure the module to the DIN rail, tighten the two hooks on the side of the IDC10 rear connector.

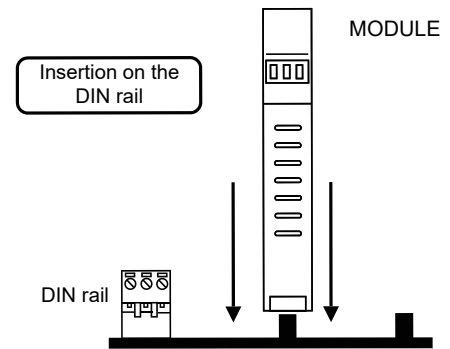

USB PORT

The module is designed to exchange data according to the modes defined by the MODBUS protocol. It has a micro USB connector on the front panel and can be configured using applications and/or software programs. The USB communication has priority over the RS485 communication.

The USB serial port uses the communication parameters shown in the table on page 8.

The USB communication port responds exactly like the RS485 port with the exception of the communication parameters. During the use of the USB port, the bus will be inactive; it will reactivate automatically after disconnecting the USB port cable. EASY SETUP (for Windows systems) is the software to be used for the configuration and calibration of the load cell. For more information, visit www.seneca.it/products/z-sg or www.seneca.it/products/sg2.

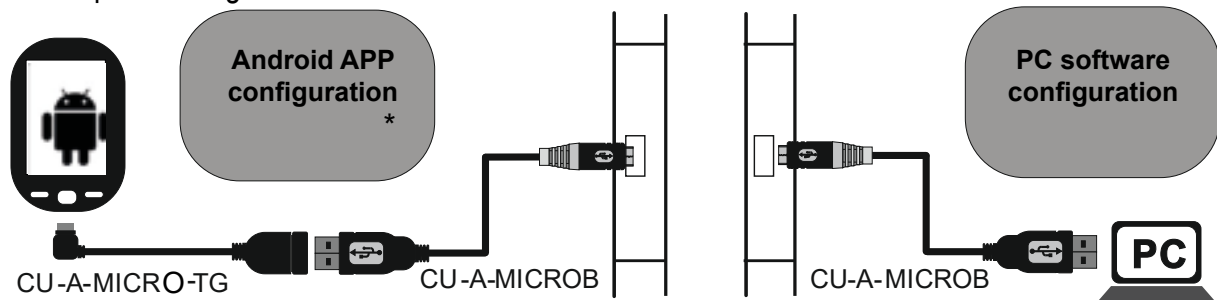

(* Check that the device in question is included in the list of products supported by the Easy Setup APP in the store.

ELECTRICAL CONNECTIONS

Power supply and Modbus interface are available using the Seneca DIN rail bus, via the IDC10 rear connector, or the Z-PC-DINAL-17.5 accessory.

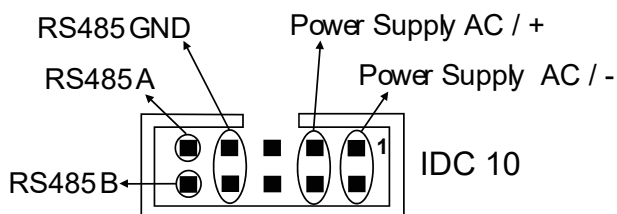

Back connector (IDC 10)

The illustration shows the meanings of the various IDC10 connector pins if signals are to be sent via them directly.

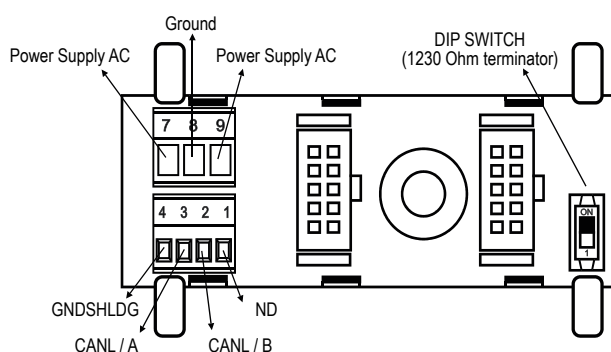

Z-PC-DINAL2-17.5 accessory use

If the Z-PC-DINAL2-17.5 accessory is used, signals can be sent via terminal boards. The illustration shows the meaning of the various terminals and DIP-switch position (found in all supports for the DIN rail listed in Accessories) for the termination of the CAN network (not used for the Modbus network).

GNDSHLDG:

Connection cable signal protection shield (recommended).



Power supply

Terminals 2 and 3 can be used to provide the module with power supply as an alternative to the connection using the Z-PC-DINx bus. **The upper limits must not be exceeded as this can seriously damage the module.** If the power supply source is not protected against overload, a safety fuse with a 2.5 max permissible value must be installed in the power supply line.

voltage output

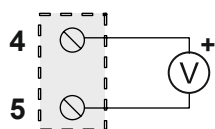

Output

The module provides a retransmitted voltage (configurable in the 0 - 10 Vac range) or current (configurable in the 0 - 20 mA, range) output. For the electrical connections, screened cables are recommended.

current output

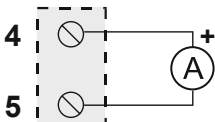

Digital input/output

Depending on the settings, it is possible to decide whether to have a digital output or input. The connections in the two cases are shown below:

Digital Input

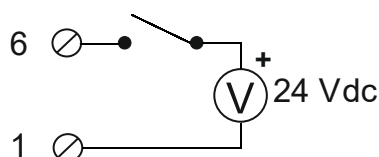

Digital Output

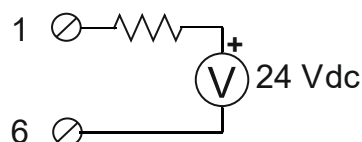

Connection to the load cell via 4 or 6 wires:

The figure shows the connections to be made for a connection to a load cell. The terminals have the following meaning:

- 7: Load cell positive supply
- 8: Load cell positive supply reading
- 9: Cell reading positive
- 10: Load cell negative supply
- 11: Load cell negative supply reading
- 12: Cell reading negative

For the connections, the use of screened cables is required.

4-wire measurement

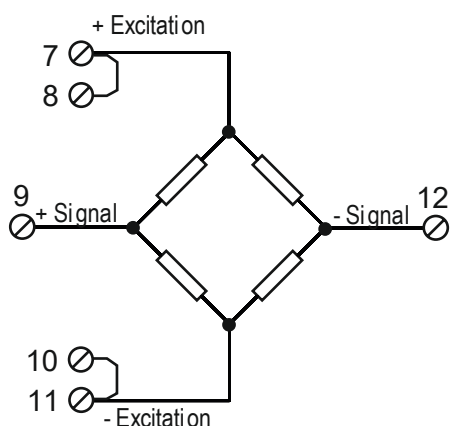

6-wire measurement

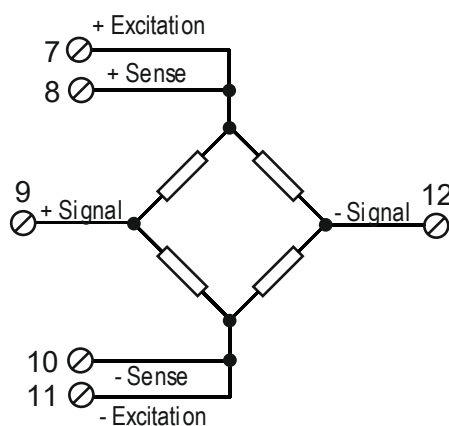

ATTENTION

The upper power supply limits must not be exceeded, as this might cause serious damage to the module. Switch the module off before connecting inputs and outputs.

To meet the electromagnetic immunity requirements:

- use shielded signal cables;
- connect the shield to a preferential instrumentation earth system;
- separate shielded cables from other cables used for power installations (inverters, motors, induction ovens, etc...).
- Make sure that the power supply voltage to the module does not exceed: 40 Vdc or 28 Vac, otherwise the module will be damaged.

CONFIGURATION OF FACTORY SETTINGS

All DIP-switches in	OFF position 
Communication parameters of ModBUS protocol:	38400 8, N, 1 Address 1
Communication parameters of micro USB front port	2400 8, N, 1 Address 1 (not configurable) (Z-SG)
	38400 8, N, 1 Address 1 (not configurable) (Z-SG)

FIRMWARE UPDATE MODE (ONLY FOR Z-SG2 VERSION)

To bring the device in Firmware update mode, follow the procedure below:

- 1) Remove power from the device
- 2) Keep the side button pressed
- 3) Power the device keeping the side button pressed
- 4) Wait a few seconds
- 5) Release the side button

To exit the firmware update mode and return to the normal device operation, just:

- 1) Turn off the device
- 2) Power the device without pressing the side button

ACCESSORIES

CODE	DESCRIPTION
CU-A-MICROB	USM - micro USB 1 metre communication cable
CU-A-MICRO-OTG	Mobile phone adapter cable
Z-PC-DINAL2-17.5	Quick fit support for DIN rail - HEAD + 2 SLOT P = 17.5 mm
Z-PC-DIN2-17.5	Quick fit support for DIN rail - 2 SLOT P = 17.5 mm
Z-PC-DIN8-17.5	Quick fit support for DIN rail - 8 SLOT P = 17.5 mm
SG-EQ4	Equalization and connection system for load cells

CONTACT INFORMATION

Technical support	support@seneca.it	Product information	sales@seneca.it
-------------------	-------------------	---------------------	-----------------

This document is the property of SENECA srl. Copies and reproduction are prohibited unless authorised. The content of this document corresponds to the described products and technologies.

Stated data may be modified or supplemented for technical and/or sales purposes.