

Input: 0-50 mV to ±10 VDC, 0-1 mA to 4-20 mA

Output: 0-1 Hz to 0-30 kHz MOSFET or TTL

- 24 Selectable Inputs and 30 Selectable Outputs
- Setup via Rotary Switches & Easy-to-Use Tables
- 2000 V Full Isolation Input/Output/Power
- Adjustable Low Frequency Cutout
- Input and Output LoopTracker® LEDs
- Functional Test Push Button

Applications

- Analog to Frequency for Totalizers and Counters
- Use With API 7580 for Remote Monitoring

DC Input Ranges

Voltage: 0-50 mVDC to ±10 VDC
 Current: 0-1 mADC to 0-20 mADC including 4-20 mA
 mA input may be wired for sink or source

Consult factory for other ranges
 System voltages must not exceed socket voltage rating

Input Impedance

Voltage: 1 MΩ minimum
 Current: 50 Ω typical

Input Loop Power Supply

18 VDC nom., unregulated, 25 mADC, max. ripple, <1.5 Vp-p

LoopTracker

Variable brightness LEDs indicate I/O loop level and status

Frequency Output Ranges

	Minimum	Maximum	Increments
Low range:	0-100 Hz	0-1500 Hz	100 Hz
High range:	0-2 kHz	0-30 kHz	2 kHz

Frequency Output Ranges, SS Version

	Minimum	Maximum	Increments
SS low range:	0-1 Hz	0-15 Hz	1 Hz
SS high range:	0-20 Hz	0-300 Hz	20 Hz

Output Waveform and Type

Square wave
 Normal acting, output freq. increases with increasing input

Output Driver

MOSFET output, open drain, 24 VDC maximum
 Isink 50 mA maximum
 Von 0.6 V maximum at 50 mA Isink

M02 option: TTL output 1 Vp-p to 12 Vp-p depending on load

Cutout Control

Disables output when input falls below preset level
 Adjustable from 2% to 25% of range
 Top accessible, multi-turn potentiometer

Output Calibration

Multi-turn zero and span potentiometers
 ±15% of selected span typical

Output Test

Pressing top button sets output to test level
 Potentiometer adjustable 2-100% of span

Linearity

Better than ±0.4% of span

Ambient Temperature Range and Stability

-10°C to +60°C operating ambient
 Better than ±0.02% of span per °C stability

Response Time

70 milliseconds typical
 Consult factory for faster response times

Isolation

2000 VRMS minimum
 Full isolation: power to input, power to output, input to output

Installation Environment

IP 40, requires installation in panel or enclosure
 Use with API 008 or API 008 FS socket
 Socket mounts to 35 mm DIN rail or can be surface mounted
 UL 508C pollution degree 2 environments or better

Power

Standard: 115 VAC ±10%, 50/60 Hz, 2.5 W max.
 A230 option: 230 VAC ±10%, 50/60 Hz, 2.5 W max.
 P option: 85-265 VAC 50/60 Hz, 60-300 VDC 2.5 W typ.
 D option: 9-30 VDC, 1.5 W typical

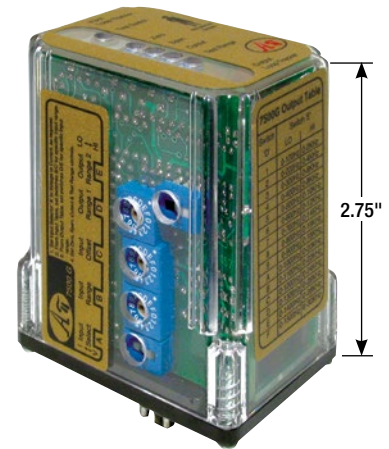
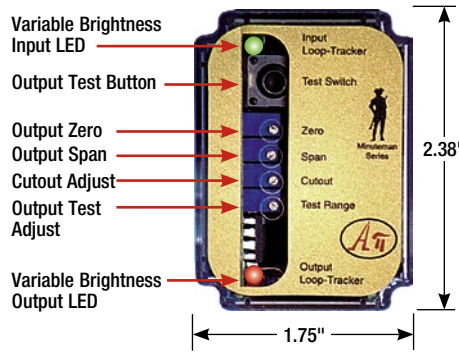

Hot Swappable Plug-In Design



UL US
 E145968
 115 VAC, 230 VAC models

Quick Link
api-usa.com/7500

Free Factory I/O Setup!

Description

The API 7500 G accepts a DC voltage or current input and provides an optically isolated frequency output that is directly proportional to the input. Common applications include pulse counting or totalizing of DC process signals from devices such as flow transmitters, analog signal transmission over long distances, or analog inputs into PLCs. The full 3-way (input, output, power) isolation makes this module useful for ground loop elimination, common mode signal rejection, and noise pickup reduction.

A low frequency cutout potentiometer can be adjusted to disable the output when the input falls below a pre-determined level. The API 7500 G can be field-configured via external rotary and slide switches. Common ranges are on the module label, however, virtually unlimited combinations are possible.

The API 7500 G has an open drain MOSFET (open collector) output which requires a user supplied external power supply and pull-up resistor allowing the module to be interfaced with a wide variety of devices. For a TTL powered output, order the M02 option.

Sink/Source Versatility





For maximum versatility the input can be selectively wired for sinking (unpowered) or sourcing (powered) milliamp output. The 18 VDC loop excitation supply can be used to power a milliamp current loop if required. The input can also be wired for an externally powered loop.

LoopTracker

API exclusive features include two LoopTracker LEDs (green for input, red for output) that vary in intensity with changes in the process input and output signals. These provide a quick visual picture of your process loop at all times and can greatly aid in saving time during initial startup and/or troubleshooting.

Output Test

An API exclusive feature includes the test button to provide a fixed output (independent of the input) when held depressed. The test output level is potentiometer adjustable from 0 to 100% of the output span. The output test button greatly aids in saving time during initial startup and/or troubleshooting.

Model	Input	Output	Power
API 7500 G	Field rangeable voltage or milliamps 0-50 mVDC to ±10 VDC 0-1 mADC to 0-20 mADC	Field rangeable 0-100 Hz to 0-30 kHz	115 VAC 
API 7500 G A230			230 VAC 
API 7500 G P			85-265 VAC or 60-300 VDC
API 7500 G D		Field rangeable Low range version 0-1 Hz to 0-300 Hz	9-30 VDC
API 7500 G SS			115 VAC 
API 7500 G SS A230			230 VAC 
API 7500 G SS P	85-265 VAC or 60-300 VDC		
API 7500 G SS D	9-30 VDC		

Options—add to end of model number

- M02** TTL powered output instead of MOSFET output
- M03** Adjustable signal generator, no input
- U** Conformal coating for moisture resistance

Accessories—order as separate line item

- API 008** 8-pin socket
- API 008 FS** 8-pin finger-safe socket
- API CLP1** Module hold-down spring for high vibration or mobile applications



API 008 FS
300 V Rating



API 008
600 V Rating



API CLP1

Precautions

WARNING! All wiring must be performed by a qualified electrician or instrumentation engineer. See diagram for terminal designations and wiring examples. Consult factory for assistance.

WARNING! Avoid shock hazards! Turn signal input, output, and power off before connecting or disconnecting wiring, or removing or installing module.

Précautions

ATTENTION! Tout le câblage doit être effectué par un électricien ou ingénieur en instrumentation qualifié. Voir le diagramme pour désignations des bornes et des exemples de câblage. Consulter l'usine pour assistance.

ATTENTION! Éviter les risques de choc! Fermez le signal d'entrée, le signal de sortie et l'alimentation électrique avant de connecter ou de déconnecter le câblage, ou de retirer ou d'installer le module.

API maintains a constant effort to upgrade and improve its products. Specifications are subject to change without notice. See api-usa.com for latest product information. Consult factory for your specific requirements.

WARNING! This product can expose you to chemicals including lead and nickel, which are known to the State of California to cause cancer or birth defects or other reproductive harm. For more information go to www.P65Warnings.ca.gov

I/O Range Switch Settings

It is easier to select ranges before installation. Ranges are listed below and the module side label lists common ranges. See the model/serial number label for module options, or if a custom range was specified.

Three rotary switches and two slide switches located on the side of the module are used to select input and output ranges. For ranges that fall between the listed ranges use the next highest setting and trim the output signal with the zero and span potentiometers.

1. Set slide switch A to current "I" or voltage "V" depending on input type. The input selector switch determines the input impedance for the module, typically 50 Ω for current inputs and 1 MΩ or greater for voltage.
2. From the table, find the rotary switch settings that match your input range and set Input B and Offset C.
3. From the table, find your frequency output range and set slide switch E to HI or LO to match your frequency output range.
4. From the table, find your frequency range and set rotary switch D to match your frequency output range.

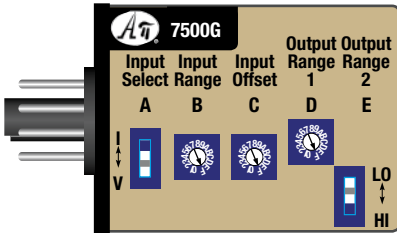

Electrical Connections

Polarity must be observed for input and output wiring connections. If the input and/or output do not function, check wiring polarity.

Socket and Mounting

Install module in a protective panel or enclosure. Allow space around module for air flow. Use API 008 or API 008 FS socket. See specifications for maximum allowable socket voltages. The socket clips to a standard 35 mm DIN rail or can be mounted to a flat surface.

Input Wiring

See the wiring diagrams. Polarity must be observed when connecting the signal input. The API 7500 G input can be wired to provide power to drive a current loop. It can also be wired to a device that provides loop power.

Determine if your device provides power to the current loop or if the loop must be powered by the API module. Use a multi-meter to check for voltage at your device's output terminals. Typical voltage may be 9-24 VDC if it provides power to the loop.

mV Input	ABC	Volt Input	ABC	mA Input	ABC
0-50 mV	V80	0-1 V	V10	0-1 mA	I0
0-100 mV	V90	0-2 V	V20	0-2 mA	I00
0-200 mV	VA0	0-2.5 V	V40	0-4 mA	I10
0-250 mV	VC0	0-4 V	V30	0-8 mA	I20
0-400 mV	VB0	1-5 V	V3D	2-10 mA	I2D
0-500 mV	V00	0-5 V	V50	0-10 mA	I40
		0-10 V	V60	0-16 mA	I30
		±5 V	V64	0-20 mA	I50
		±10 V	V74	4-20 mA	I3D

Standard Output

Polarity must be observed when connecting the signal output to the load. The positive connection (+) is connected to terminal 7 and the negative (-) is connected to terminal 8.

The standard API 7500 G has an open drain MOSFET (open collector) output. This output requires a user-supplied external power supply and pull-up resistor unless your input device is compatible with this type of output. The output signal is protected to a maximum of 24 V. See wiring diagram below.

API 7500 G Output LO	DE	API 7500 G Output HI	DE
0-100 Hz	1L	0-2 kHz	1H
0-200 Hz	2L	0-4 kHz	2H
0-300 Hz	3L	0-6 kHz	3H
0-400 Hz	4L	0-8 kHz	4H
0-500 Hz	5L	0-10 kHz	5H
0-600 Hz	6L	0-12 kHz	6H
0-700 Hz	7L	0-14 kHz	7H
0-800 Hz	8L	0-16 kHz	8H
0-900 Hz	9L	0-18 kHz	9H
0-1000 Hz	AL	0-20 kHz	AH
0-1100 Hz	BL	0-22 kHz	BH
0-1200 Hz	CL	0-24 kHz	CH
0-1300 Hz	DL	0-26 kHz	DH
0-1400 Hz	EL	0-28 kHz	EH
0-1500 Hz	FL	0-30 kHz	FH

API 7500 G SS Output LO	DE	API 7500 G SS Output HI	DE
0-1 Hz	1L	0-20 Hz	1H
0-2 Hz	2L	0-40 Hz	2H
0-3 Hz	3L	0-60 Hz	3H
0-4 Hz	4L	0-80 Hz	4H
0-5 Hz	5L	0-100 Hz	5H
0-6 Hz	6L	0-120 Hz	6H
0-7 Hz	7L	0-140 Hz	7H
0-8 Hz	8L	0-160 Hz	8H
0-9 Hz	9L	0-180 Hz	9H
0-10 Hz	AL	0-200 Hz	AH
0-11 Hz	BL	0-220 Hz	BH
0-12 Hz	CL	0-240 Hz	CH
0-13 Hz	DL	0-260 Hz	DH
0-14 Hz	EL	0-280 Hz	EH
0-15 Hz	FL	0-300 Hz	FH

M02 Option TTL Output

The M02 TTL output option uses an internal power supply and an internal pull up resistor. An external power supply is not needed. The output amplitude can vary from 1 VDC to 12 VDC depending on the input impedance of your device. Maximum current drive capability is 10 mA.

Module Power

Check model/serial number label for module operating voltage to make sure it matches available power.

AC power is connected to terminals 1 and 3.

For DC powered modules, polarity MUST be observed. Positive (+) is wired to terminal 1 and negative (-) is wired to terminal 3.

Output Calibration

Input and output ranges, if specified on your order, are factory pre-configured (at 24°C ±1°C). Top-mounted zero and span potentiometers can be used should fine-tuning the output be necessary.

Note: Perform the following calibration procedure any time switch settings are changed.

1. Apply power to the module and allow a minimum 20 minute warm up time.
2. Using an accurate calibration source, provide an input to the module equal to the minimum input required for the application.
3. Using an accurate frequency measurement device for the output, adjust the Zero potentiometer for the exact minimum output desired. The Zero control should only be adjusted when the input signal is at its minimum. This will produce the corresponding minimum output signal of 0 Hz.
4. Set the input at maximum, and then adjust the Span pot for the exact maximum output desired. The Span control should only be adjusted when the input signal is at its maximum. This will produce the corresponding maximum output signal.
5. Repeat adjustments for maximum accuracy.

Cutout Control

This multi-turn potentiometer provides the user with a low threshold adjustment. It disables output when input falls below a preset level. The low cutout potentiometer is adjustable from 2% to 25% of input range. The input signal must overcome this setting to produce an output from the unit.

Output Test Function

When the Test button is depressed it will drive the output with a known good signal that can be used as a diagnostic aid during initial start-up or troubleshooting. When released, the output will return to normal. Additionally external contacts across terminals 5 and 6 can be used as a remote test function or manual override.

The Test Cal. potentiometer is factory set to approximately 50% output. It can be adjusted to set the test output from 2 to 100% of the output span. Press and hold the Test button and adjust the Test Cal. potentiometer for the desired output level.

Operation

The API 7500 G accepts a DC voltage or current input and provides an optically isolated frequency output that is linearly related to the input. Note the output duty cycle decreases as the frequency increases in the high ranges.

The variable brightness green LoopTracker® input LED provides a visual indication of the input level. It changes in intensity as the input changes from minimum to maximum. If the LED fails to illuminate, or change in intensity as the input changes, it may indicate a problem with module power, or signal input wiring.

Note that it may be difficult to see the LEDs under bright lighting conditions.

The red LoopTracker output LED provides a visual indication that the output frequency signal is functioning. It becomes brighter as the input and the corresponding output change from minimum to maximum.

Failure to illuminate or a failure to change in intensity as the process changes may indicate a problem with the module power or signal output wiring.

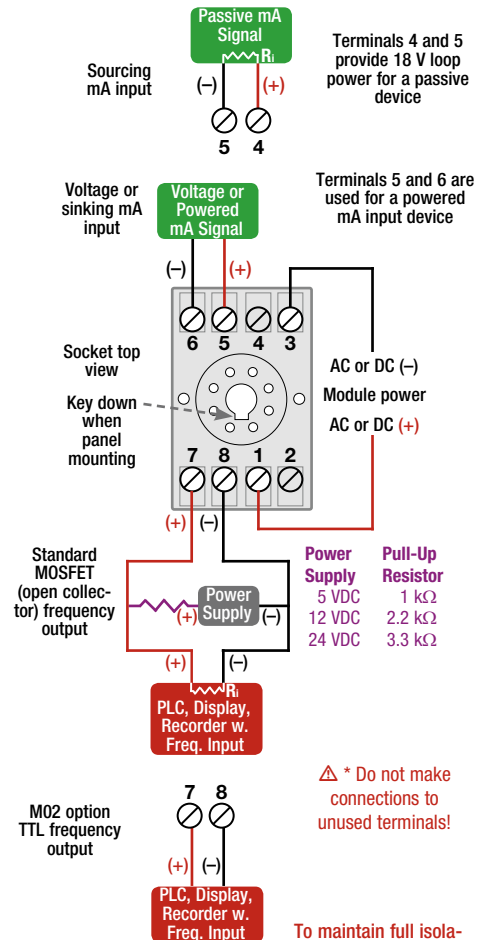

⚠ * Do not make connections to unused terminals!

To maintain full isolation avoid combining power supplies in common with input, output, or unit power.