

- General Info
- Temperature
- Pressure
- Flow
- Speed
- Weighing
- Process

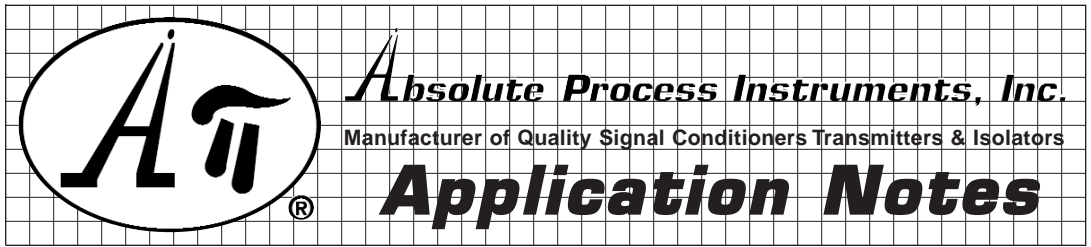

## **Calibration of a Pressure Transducer**

### **PROBLEM**

The pressure of a critical process is to be monitored by a computer. To ensure accuracy and reliability, attention has to be paid to the entire system calibration. How can the pressure system be calibrated using the internal calibration resistor of the pressure transducer?

### **SOLUTION**

The **API 4051 G M02** Strain Gauge (Bridge) Input to DC Transmitter module provides the stable excitation voltage for the pressure transducer and produces the required 0-10 VDC output for the computer.

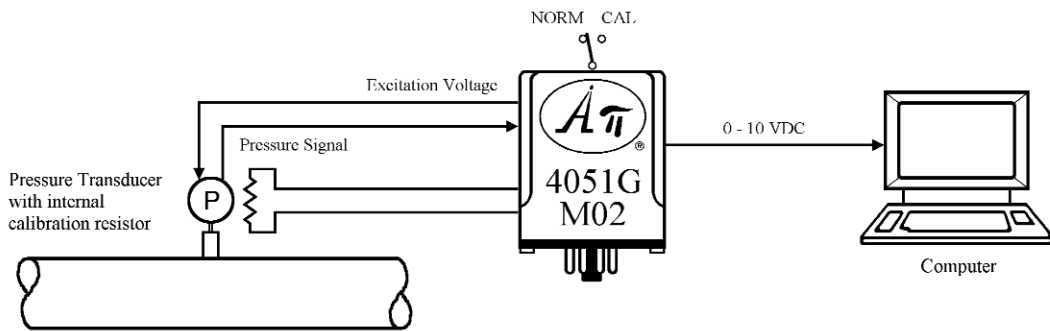

The **API 4051 G M02** utilizes the pressure transducer's internal calibration resistor to unbalance the bridge to a specified value when the test switch is in the CAL position, ensuring accurate system calibration.



**FREE APPLICATION ASSISTANCE**  
 Call  **Customer Service**  
**800-942-0315**

### **Did You Know...?**

All Api plug-in and DIN style modules are covered by a LIFETIME WARRANTY.