

# Valve Positioner/Actuator/Controller

API 3200 G



**Input:** 0-1 V to 0-100 VDC or 0-10 mA to 0-1 ADC  
**Output:** 7 A SPDT Relay with Neutral Position

**Potentiometer or Optional  
 Current or Voltage Feedback**

- Automatic or Manual Valve Control
- Test/Manual Positioning Pushbuttons
- Input LoopTracker® LED
- Relay Status LEDs
- High Capacity Relay Contacts

## Applications

- Valve Position Controller
- Linear Actuator Controller
- Damper Controller

## Specifications

### Control Input

Factory Configured—Please specify input range  
 System voltages must not exceed socket voltage rating

<b>API 3200 G</b>	Minimum	Maximum
Voltage:	0-1 VDC	0-100 VDC
Current:	0-10 mA	0-1 ADC

### API 3200 G M01

Voltage: 0-1 V, 0-5 V, 1-5 V, 0-10 V

### API 3200 G M420

Current: 0-20 mA, 4-20, mA, 10-50 mA

### Input Impedance

Voltage inputs: 200 kΩ minimum      Current inputs: 50 Ω

### Input Voltage Burden (Current)

1.25 VDC maximum

### Input Zero and Span

Single turn potentiometers to compensate for load and lead variations  
 ±10% of span adjustment range typical

### LoopTracker

Variable brightness LED indicates input level and status

### Feedback

#### API 3200 G

Potentiometer Range: 0-100 Ω to 0-100 kΩ  
 Potentiometer Excitation: 1.0 VDC nominal, 10 mA maximum

#### API 3200 G M01

Voltage: 0-1 V, 0-5 V, 1-5 V, 0-10 V

#### API 3200 G M420

Current: 0-20 mA, 4-20, mA, 10-50 mA

### Relay Output

SPDT relay with neutral contact position  
 7 A @ 240 VAC maximum resistive load  
 3.5 A @ 240 VAC maximum inductive load

CAUTION: Socket contacts may limit system rating.  
 External contact protection such as an RC snubber is recommended for inductive loads.

### Deadband

12 turn potentiometer, adjustable from 1 to 25% of span

### Operational Controls

Automatic/manual switch, Open/close pushbuttons

### Response Time

100 milliseconds typical

### Ambient Temperature Range and Stability

-10°C to +60°C operating ambient  
 Better than ±0.02% of span per °C stability

### Power

Standard: 115 VAC ±10%, 50/60 Hz, 2.5 W max.  
**P** option: Powered by 80-265 VAC or 48-300 VDC, 50/60 Hz  
**A230** option: 230 VAC ±10%, 50/60 Hz, 2.5 W max.  
**D** option: 9-30 VDC, 2.5 W typical

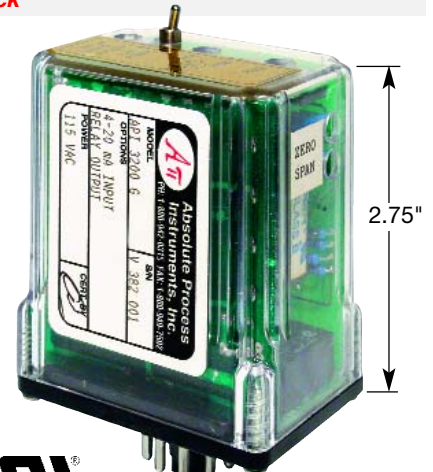
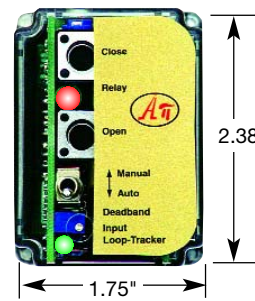

## Description and Features

The **API 3200 G** controls the position of a valve or linear actuator by comparing a DC input (control signal) to that of a position feedback potentiometer or slidewire. An SPDT relay provides bi-directional (open-close) signals to drive a motor to open or close a valve.

When the valve position, as indicated by the feedback potentiometer, becomes equal to the position as represented by the control input, the relay will go to the neutral position and the motor will halt. A top-accessible multi-turn deadband control allows precise positioning of the motor without hunting or oscillation.

The **API 3200 G M420** controls the position of a valve or linear actuator by comparing a DC current input (control signal) to that of a current feedback signal. The **API 3200 G M01** controls the position of a valve or linear actuator by comparing a DC voltage input (control signal) to that of a voltage feedback signal.

All versions of the **API 3200 G** have heavy-duty relay contacts (7 A at 240 VAC, resistive load) allow the modules to directly control high capacity loads without a secondary device. Caution must be exercised when sizing inductive loads (motor loads). For assistance, contact the factory.

A top-accessible Auto/Manual switch allows either closed-loop automatic control of valve position or manual positioning via the Open/Close pushbuttons. The manual mode is useful for troubleshooting, calibration, system testing or as a manual bypass. A bi-color LED indicates the Open/Close relay contact status.

A green **LoopTracker** LED varies in intensity with changes in the control input signal. Monitoring this LED can provide a quick visual picture of your process at all times and save time during initial startup and/or troubleshooting.

Industry standard 11-pin sockets **API 011** and finger-safe **API 011 FS** allow either DIN rail or panel mounting and are sold separately.

## Models & Options

Factory Configured—Please specify if non-standard input

<b>API 3200 G</b>	DC input valve controller, potentiometer feedback. SPDT relay output, 115 VAC
<b>API 3200 G M01</b>	DC input valve controller, 1-5 V feedback or specify. SPDT relay output, 115 VAC
<b>API 3200 G M420</b>	DC input valve controller, 4-20 mA feedback or specify. SPDT relay output, 115 VAC

Options—Add to end of model number

<b>P</b>	Powered by 80-265 VAC or 48-300 VDC, 50/60 Hz
<b>A230</b>	Powered by 230 VAC, 50/60 Hz
<b>D</b>	Powered by 9-30 VDC
<b>U</b>	Conformal coating for moisture resistance

Accessories—Order as a separate line item

<b>API 011</b>	11-pin socket
<b>API 011 FS</b>	11-pin finger safe socket
<b>API TK36</b>	DIN rail, 35 mm W x 39" L, aluminum



## ELECTRICAL CONNECTIONS

**WARNING!** All wiring must be performed by qualified personnel only. This module requires an industry-standard 11-pin socket. Order API 011 or finger-safe API 011 FS socket separately.

**Power Input Terminals** – The white label on the side of the API module will indicate the power requirements. AC power is connected to terminals 1 and 3. For DC powered modules, polarity **MUST** be observed. Positive (+) is wired to terminal 1 and negative (-) is wired to terminal 3.

**Control Input** – Terminals 4 and 5 provide the appropriate connections for the input signal. Polarity must be observed when connecting the signal input. The positive connection (+) is applied to terminal 4 and the negative (-) is applied to terminal 5.

**Feedback Signal** – Terminals 6, 7, 8 provide the appropriate connections for the desired motor operations.

**Relay Output Terminals** – Terminals 9, 10, 11 provide the appropriate connections for the desired motor operations. (NO = Normally Open, NC = Normally Closed, C = Common).

## CALIBRATION

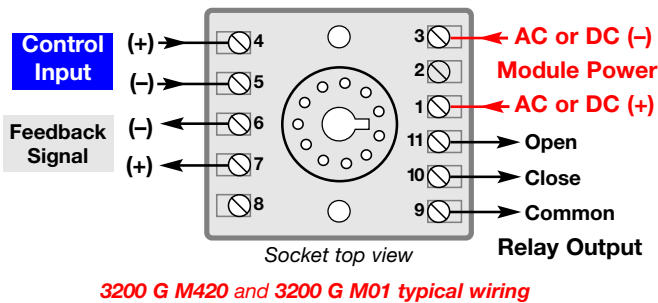
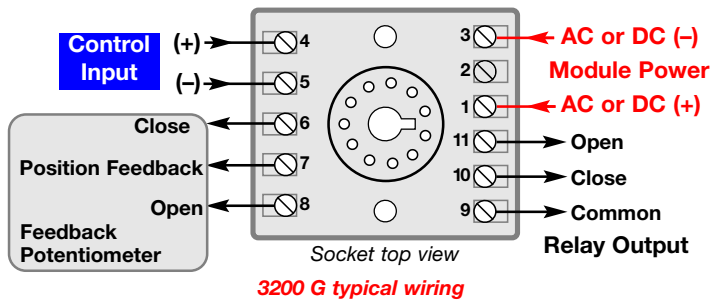

**Deadband** – For most applications the deadband is the only required adjustment.

1. Deadband is normally adjusted after installation is complete.
2. Turn the deadband potentiometer counterclockwise to minimum.
3. Provide a near mid-level control input signal.
4. Allow the valve to stabilize.
5. If overshoot, oscillation, or hunting are detected, slowly increase the deadband clockwise to eliminate the oscillation.

**Zero and Span** – Zero and span adjustments are located on the side of the case and normally do not need to be adjusted.

1. If adjustment is required, apply a control input that represents the fully closed position.
2. Adjust the zero control to just close the valve.
3. Apply a full open control input signal.
4. Adjust the span control to just fully open the valve.

## OPERATION

The API 3200 G provides an excitation voltage to the feedback potentiometer on the valve or valve actuator and monitors its position. If the difference between the control signal and the feedback signal is greater than the deadband setting, the appropriate relay is energized to actuate the positioning motor.

The API 3200 G M420 uses a 4-20 mA control signal input and feedback signal (unless another current range was specified). The difference between the control signal input and the feedback signal is compared to the deadband setting. If the difference between the two is greater than the deadband setting, the appropriate relay contact is energized to actuate the positioning motor.

API 3200 G M01 has a 1-5 volt feedback signal and control signal input (unless another voltage range was specified). The difference between the control signal input and the feedback signal is compared to the deadband setting. If the difference between the two is greater than the deadband setting, the appropriate relay contact is energized to actuate the positioning motor.

**GREEN LoopTracker® Input LED** – Provides a visual indication that a signal is being sensed by the input circuitry of the module. It also indicates the input signal strength by changing in intensity as the process changes from minimum to maximum to provide a quick visual picture of your process loop at all times. If the LED fails to illuminate, or fails to change in intensity as the process changes, this may indicate a problem with module power or signal input wiring. This features greatly aid in saving time during initial start-up or troubleshooting.

**Control Relays** – For all versions an electronic lockout circuit is used to prevent both relay contacts from closing simultaneously. When the input and the feedback signals are equal, the relay contacts will go to the neutral position.

**Bi-Color Relay LED** – Provides a visual indication of the relay status. In all configurations, a GREEN LED indicates a valve open relay position and a RED LED indicates a valve close relay position. In the neutral position, the LED will be off.

**Manual/Auto Mode** – Switching the top-mounted toggle switch to Manual allows the Open and Close pushbuttons to be used to position the valve independent of the control and feedback signals. The manual mode is useful for troubleshooting, calibration, system testing, or as a manual bypass. The bi-color relay LED indicates the controller's Open/Close relay contact status. Switching to Auto mode allows normal operation.

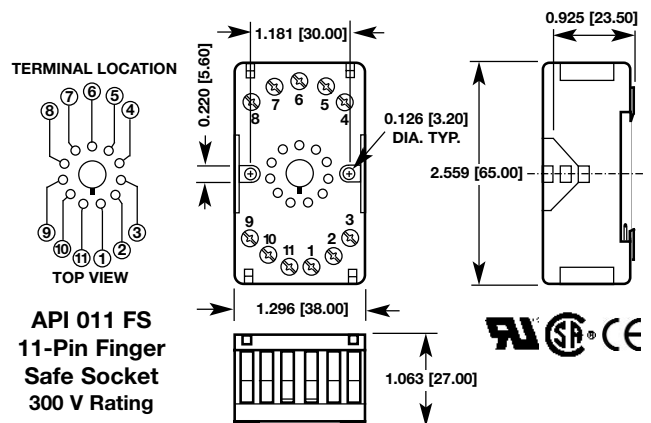
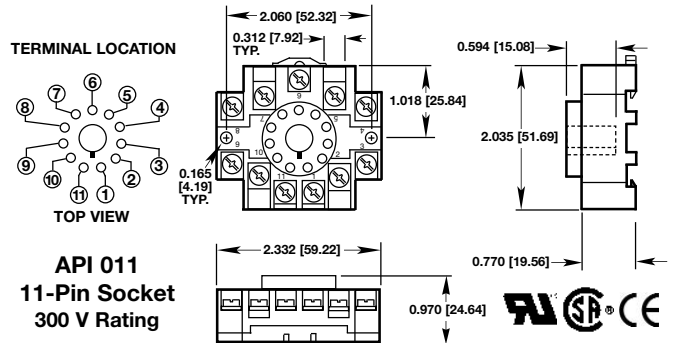

API maintains a constant effort to upgrade and improve its products. Specifications are subject to change without notice. Consult factory for your specific requirements.



**Flow Control with Flow Meter Feedback**

**PROBLEM**

Operate a valve to accurately control the flow of liquid chemical in a pipeline where the feedback signal is 4-20 mA from a flow meter.

**SOLUTION**

An API 3200 G M420 Valve/Actuator Positioner/Controller module compares the 4-20 mA flow command signal from the process control computer to the 4-20 mA flow feedback signal from the flow meter.

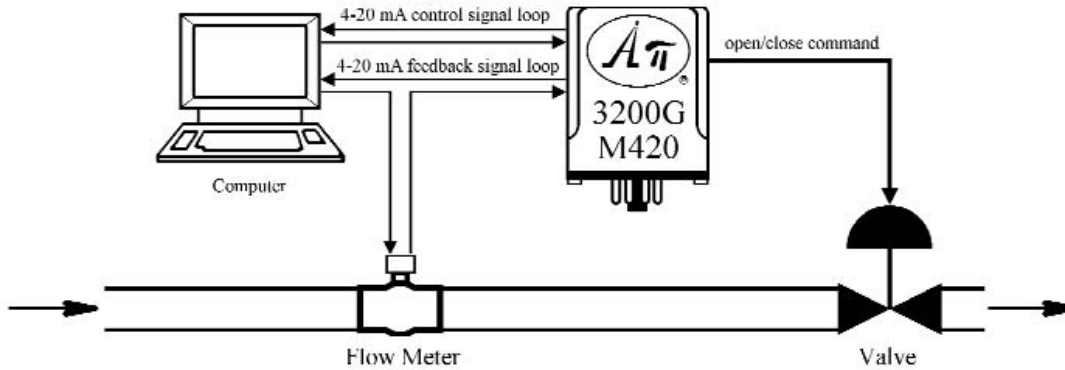

The API 3200 G M420 positions the valve as necessary to match the feedback signal to the command signal.

**Maintaining a Constant Differential Temperature Across a Heat Exchanger**

**PROBLEM**

A critical process requires precise control of the change in temperature of the process fluid across a heat exchanger.

**SOLUTION**

Install RTDs at the process fluid heat exchanger inlet and outlet and connect the RTDs to an API 4001G SA-B Non-Isolated Differential RTD to DC Transmitter module.

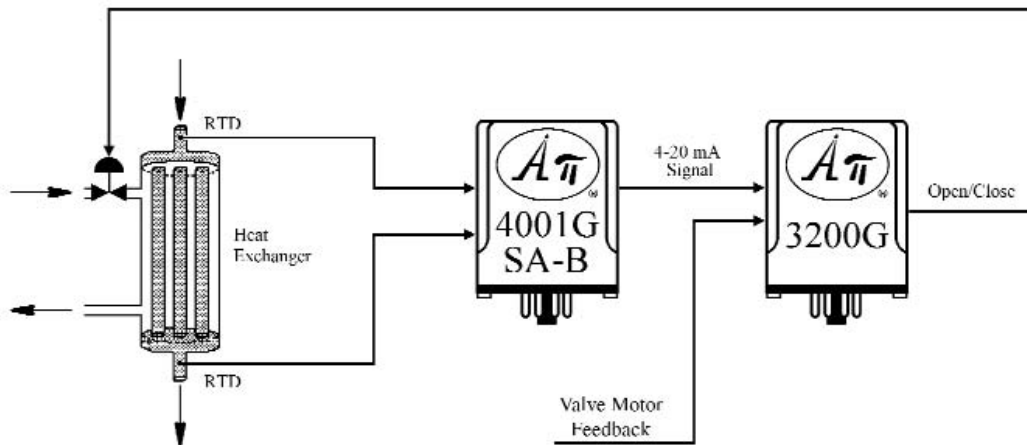

The API 4001 G SA-B computes the differential temperature and provides a proportional 4-20 mA output signal which is used by the API 3200 G Valve/Actuator Positioner/Controller module to drive the temperature control valve open or closed as necessary to maintain the required process fluid temperature differential.

**FREE APPLICATION ASSISTANCE**  
 Call Customer Service  
**800-942-0315**

API maintains a constant effort to upgrade and improve its products. Specifications are subject to change without notice. Consult factory for your specific requirements.

For Your Local Area Representative See [www.api-usa.com](http://www.api-usa.com)



## Fail Safe Valve Control

### PROBLEM

For safety reasons an automated normally closed valve used in a coal mining operation must go to the full open position if the control signal from the programmable logic controller (PLC) is lost.

### SOLUTION

The valve is controlled by an **API 3200 G** Valve/Actuator Positioner/Controller module. The input to the **API 3200 G** comes through an **API 1000 G** DC Input Single Alarm Trip module, which selects either the PLC output or a constant 20 mA output from an **API 4003 GIS** DC Special Transmitter module.

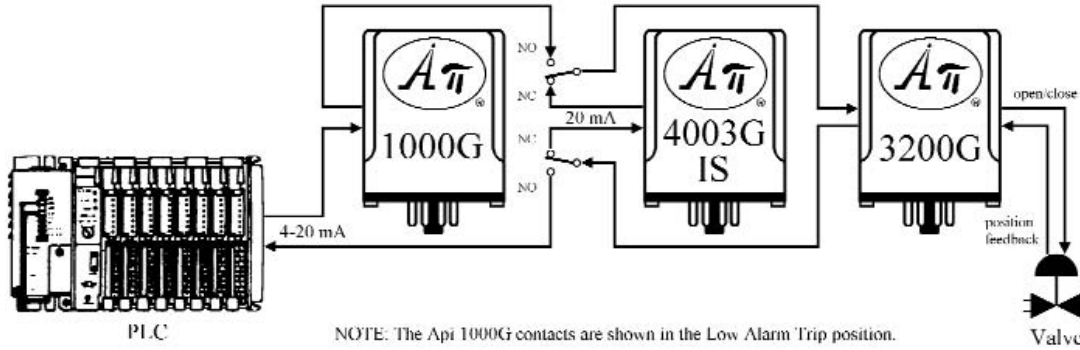

If the signal from the PLC drops below 4 mA, the **API 1000 G** will trip to a low alarm state, and select the 20 mA signal for the **API 3200 G**, thus commanding the valve to open fully. When the signal from the PLC is 4 mA or greater, the **API 1000 G** selects the PLC output signal for the **API 3200 G**, thus controlling valve position as normal.

## Frequently Asked Questions – Valve Actuator

**We have an API 3200 G M01 with a 0-10 VDC feedback signal and a 0-10 VDC control input. How do we calibrate this?**

1. Set the deadband potentiometer fully CCW (counter-clockwise).
2. Apply the minimum signal (0 VDC) to both the feedback (terminals 6 & 7) and the control (terminals 4 & 5).
3. Turn the zero potentiometer screw until the relay changes state and has continuity from the common to the close position. The relay LED will be red to indicate the close position.
4. Apply the maximum signal (10 VDC) to both the feedback and the control inputs.
5. Turn the span potentiometer screw until the relay changes state and has continuity from the common to the open position. The relay LED will be green signaling the open position.
6. Apply 5 VDC to both the feedback and the control inputs. The relay contact should have no continuity and the relay LED should be off.
7. Use your multimeter to measure across terminals 4 and 7. The positive connections for both the feedback and the control should be within the minimum deadband (about 1% of span) for no relay change of state.
8. Change the feedback voltage to the desired deadband position. Rotate the deadband potentiometer CW (clockwise) until the relay changes state.

**We would like to compare two signals. Each is 4-20 mA. If the difference between the two signals at any point in the 4-20 mA range becomes greater than the configured deadband, an output relay must change state to provide an alarm. Do you have a product to accomplish this?**

Yes. Order the **API 3200 G M420**. The deadband can be adjusted to allow for a 1 to 25% difference in the two signals. If the difference is less than the deadband configured, then both relay contacts will not have continuity with the common terminal.

If the feedback 4-20 mA loop is higher than the control input, then continuity will be from common (9) to open (11). If the feedback is less, than the control input, then continuity will be from the common (9) to closed (10).



**FREE APPLICATION ASSISTANCE**

Call **Customer Service**

**800-942-0315**

API maintains a constant effort to upgrade and improve its products. Specifications are subject to change without notice. Consult factory for your specific requirements.